

Official Worldwide Olympic Partner



60 Hz

10/2008

Multi-format Live Switcher
AV-HS400A

**Compact, High-performance, Multi-format Live Switcher
with Multi-view display**

AV-HS400A



Introducing the AV-HS400A with new and enhanced capabilities!



Multi-purpose Camera
AK-HC1500
AK-MC1800

HD Integrated Camera
AW-HE100

Multi-format HD/SD Compatibility for Worldwide Use

Compatibility with various HD/SD formats will help you meet changing production needs as video moves towards HD on a global scale. The AV-HS400A lets you up-convert and mix SD signals with HD, to provide an easy transition to full HD production. The AV-HS400A is compatible with virtually all common input devices.

Compatible formats

HD	1080/59.94i, 1080/50i, 720/59.94p, 720/50p	SD	480/59.94i, 576/50i
-----------	---	-----------	----------------------------

Built-in Frame Synchronizers for Versatile Operation

Each input features a built-in 10-bit Frame Synchronizer for smooth switching, even with asynchronous sources, such as DVDs or satellite feeds. Reference (black burst) signal outputs are provided to enable synchronization with external systems. The main unit and control panel are integrated in a compact body, ideal for small studios and mobile production.

- * AC 100 V to 120 V power supply.
- The unit is not waterproof so please avoid direct contact with water.

Remotely control the HD integrated camera AW-HE100 and pan-tilt heads*

Directly connecting the AW-HE100 3CCD integrated pan/tilt/zoom camera or a Panasonic camera/pan-tilt head* allows control over pan, tilt, zoom, and focus using the AV-HS400A's positioner.

Moreover, by also connecting a Panasonic control panel** you can switch between and operate up to 5 cameras and pan-tilt heads*.

* Compatible models: AW-PH400/AW-PH405/AW-PH360. ** Compatible models: AW-RP655/AW-RP555.

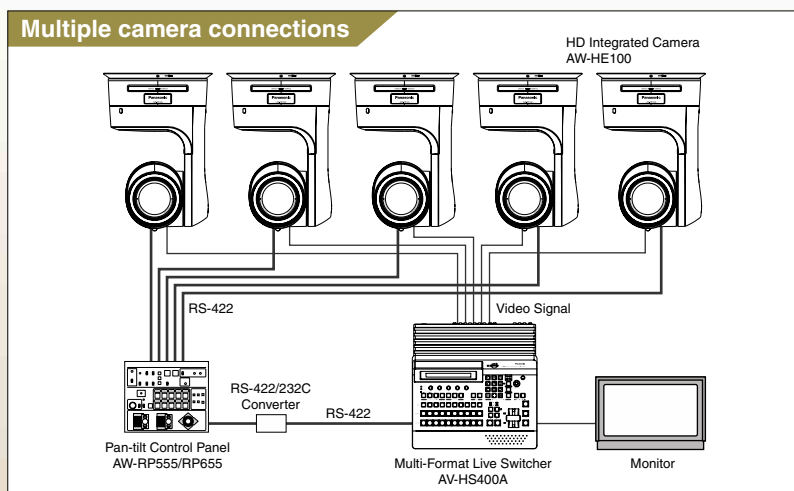
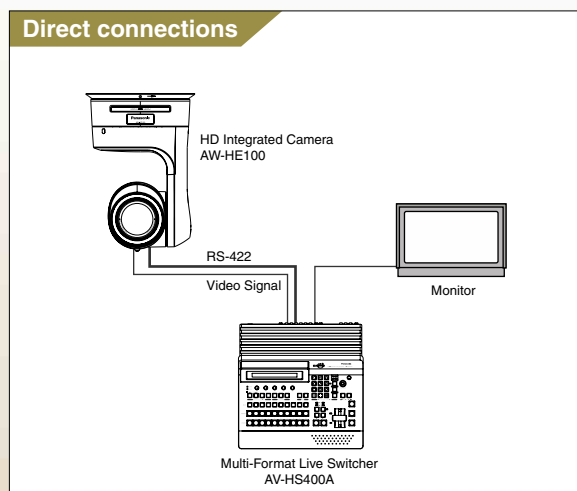

Compatible with HD/SD cameras worldwide.

Sports Arena

News Magazine Show

Worldwide Production

Educational Solution

Concert Hall



P2HD

Memory Card Camera-Recorder

SDI Standard Compatible, with up to 8 Video Inputs and Outputs.

- Standard equipment includes 4 HD/SD-SDI inputs and outputs*.
- Optional input and output expansion boards (sold separately) include:
 Input: Addition of up to 4 HD/SD-SDI inputs, up to 4 HD/SD analog components, up to 4 HD/SD analog composite, or up to 4 DVI-I**. Moreover, each optional input board is equipped with an up-converter.
 Output: Addition of up to 4 SDI, 4 Analog Component, and 2 DVI-I*** outputs, with a maximum of 8 total outputs.
- Tally outputs for up to 8 cameras for extra convenience when operating as a live switcher.
- RS-422 compatible (GVG protocol) control jack.

* Two interfaces assignable as PGM,PVV, AUX, multi-screen, and keyout. ** Compatible with XGA, WXGA, SXGA.
 *** Compatible with XGA (1024x768), WXGA (1280x768), SXGA (1280x1024), WSXGA+ (1680x1050)****, UXGA (1600x1200)****, WUXGA (1920x1200)****.
 **** Digital output only.

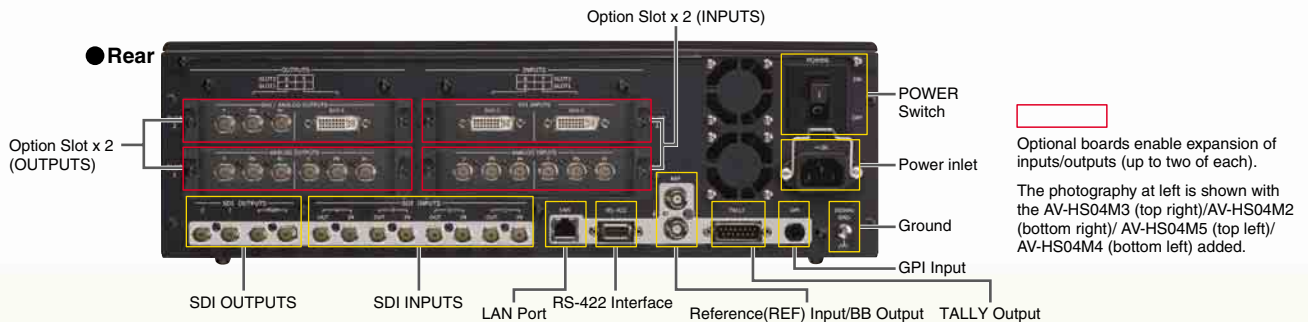

Optional boards enable expansion of inputs/outputs (up to two of each).
 The photography at left is shown with the AV-HS04M3 (top right)/AV-HS04M2 (bottom right)/ AV-HS04M5 (top left)/ AV-HS04M4 (bottom left) added.

Option Boards You can expand inputs/outputs to match your requirements.

INPUTS	 SDI INPUTS BOARD AV-HS04M1 • INPUTS : HD/SD-SDI x2 (BNC)(Built-in Up-converter)	 ANALOG INPUTS BOARD AV-HS04M2 • INPUTS : HD/SD Analog Component x2 (Y/Pb/Pr)(Built-in Up-converter)	 DVI INPUTS BOARD AV-HS04M3 • INPUTS : DVI-I x2 (Built-in Scaler)	 ANALOG COMPOSITE INPUTS BOARD AV-HS04M6 * • INPUTS : Analog Composite x2 (Built-in Up-converter)
OUTPUTS	 ANALOG OUTPUTS BOARD AV-HS04M4 • OUTPUTS : Analog Component x2 (Y/Pb/Pr)	 DVI/ANALOG OUTPUTS BOARD AV-HS04M5 • OUTPUTS : DVI-I x1, Analog Component x1 (Y/Pb/Pr)	 SDI OUTPUTS BOARD AV-HS04M7 * • OUTPUTS : HD/SD-SDI x2 (Each one has 2 outputs)(BNC) (Built-in Down-converter)	<p>*AV-HS04M6/HS04M7 is exclusively for the AV-HS400A. The AV-HS400 must be upgraded to use the AV-HS04M6/HS04M7. For details, please contact your local Panasonic reseller or representative.</p>

Multi-system compatibility for extra flexibility

It's compact with all the functions you need

■ The main unit and control panel are integrated in a compact body.



* SD Memory Card is not included.

Image file transfer via LAN*
Compatible with JPEG/TIFF/PNG/GIF/BMP.
* Comes with dedicated software.

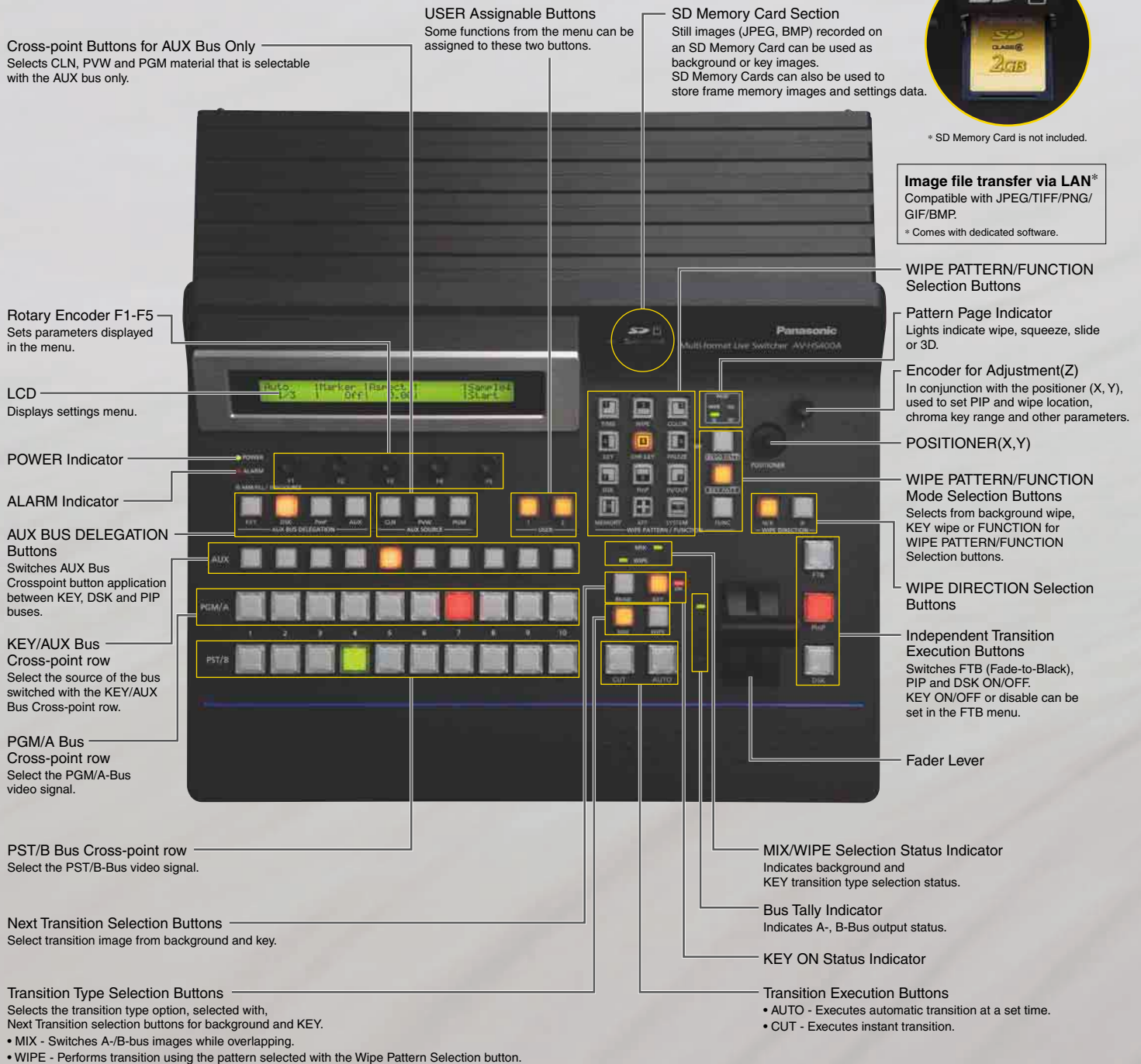

in the field and studio. for superb results.



■ Use the Multi-view Display Function to Preview Materials and Production Screen on a Single Monitor

Multi-view display enables simultaneous split-screen preview with a single monitor, so you can reduce the number of monitors required. Split-screen segments labels may now be selected or edited. Labels may also be turned off or adjusted for 5 levels of brightness. The label background "band" and frame outline may also be turned of, and the frame brightness is adjustable through 5 levels.

Example of an AV-HS400A monitor system

Simultaneous split-screen preview with a single monitor.



Example of conventional monitor system

Connection of separate monitors is required for each input, PVW and PGM.

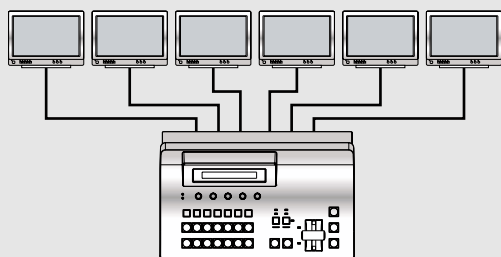

* The image shows loop-through outputs connected to switcher inputs.

■ Selectable Split-screen Quantity and Location

- The number of split-screens can selected from 10,8, and 4.
- Display of red/green tally indications in frame can be displayed.
- Split-screen labels may customized or selected from menus.
- When splitting screens into 10/8 sections, the upper 2 windows may be selected from PGM/PVW/AUX/BUS/KEYOUT images.



Ten Split Pictures (images)

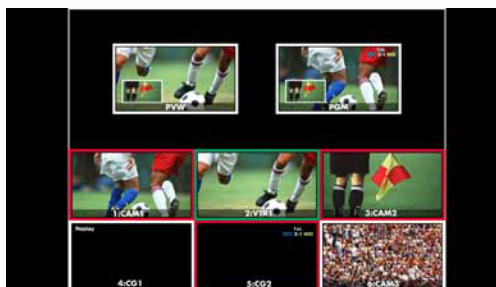

Eight Split Pictures (images)



Four Split Pictures (images)

Multiple Effects for Stunning Results

In addition to standard wipe patterns, the DVE allows you to utilize squeeze, slide effects, and different types of 3D. The 3D DVE effects (i.e. page turn) are also applicable to the key function. Keyer functions include a luminance key, chroma key, and DSK. Furthermore, the AV-HS400A offers an additional, even greater range of visual effect key functions brought to life with the flying key function, enabling easy key position and size adjustment. Enhanced key functions include omnidirectional edge control in 45 degree increments, and a simplified 2nd PiP (Picture-in-Picture.)

A total of 43 effects offer great creative flexibility

WIPE

Switching between 12 wipe patterns.



(images:pattern4)

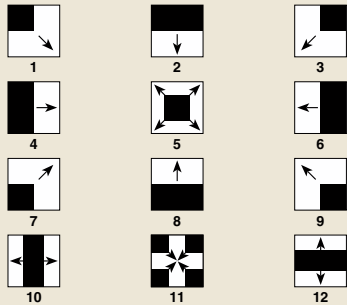

SQ (Squeeze)

Switching between 11 types of squeeze including center, top and bottom.



(images:pattern4)

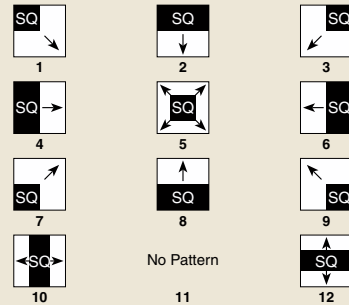

SL (Slide)

Switching between up, down, left, right and diagonal slide effects.



(images:pattern4)

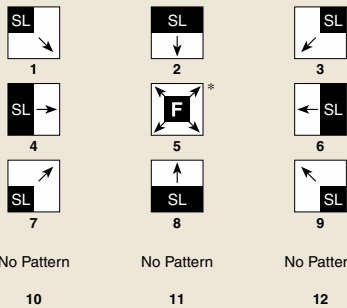

* Key transition only.

3D (3 Dimension)

Switching between 3D effects such as page turn and rotate.

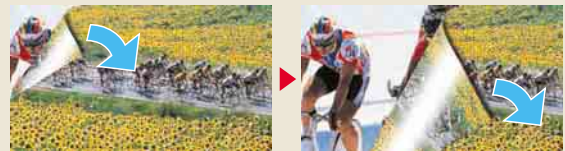

(images:pattern1)

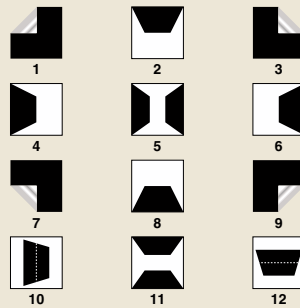

More variegated visual effects are offered by addition of 3D DVE effect to the key function.

Chroma key for broadcast quality composite images

High-quality chroma key for broadcast and commercial production applications.

Chroma key material

Background material

After composition



Example of composite effect

WIPE DSK



PiP (images)

● Ready for broadcast and studio production applications.

HD-SDI camera environment (with Genlock)

- =Option Boards
- ① SDI INPUTS (AV-HS04M1)
- ② SDI INPUTS (AV-HS04M1)
- ③ ANALOG OUTPUTS (AV-HS04M4)

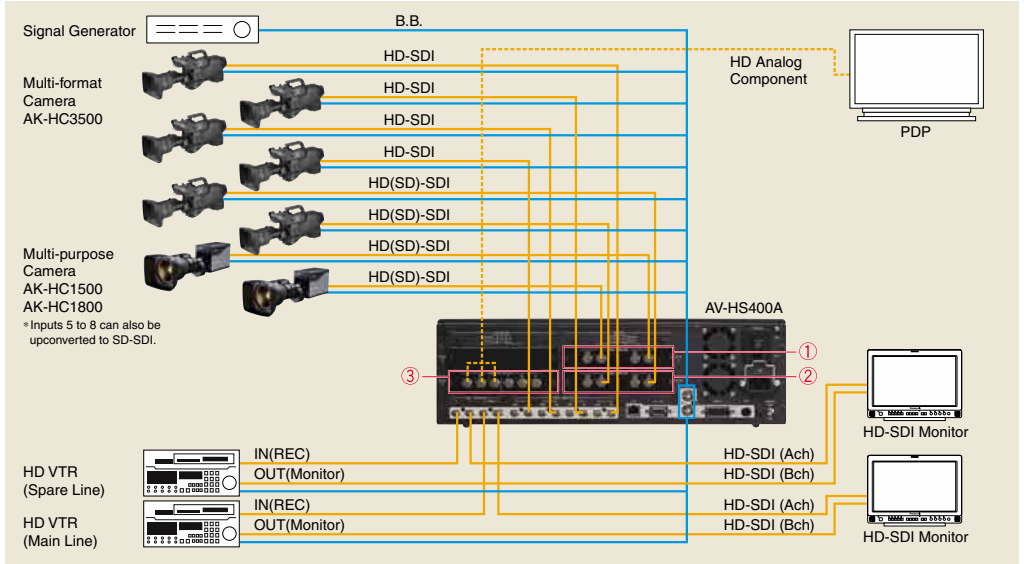

● Ideal for use with simple systems at CATV stations, schools and other locations.

HD camera environment (no Genlock): Using the HD Analog component option

- =Option Boards
- ① DVI INPUTS (AV-HS04M3)
- ② ANALOG INPUTS (AV-HS04M2)
- ③ DVI/ANALOG OUTPUTS (AV-HS04M5)

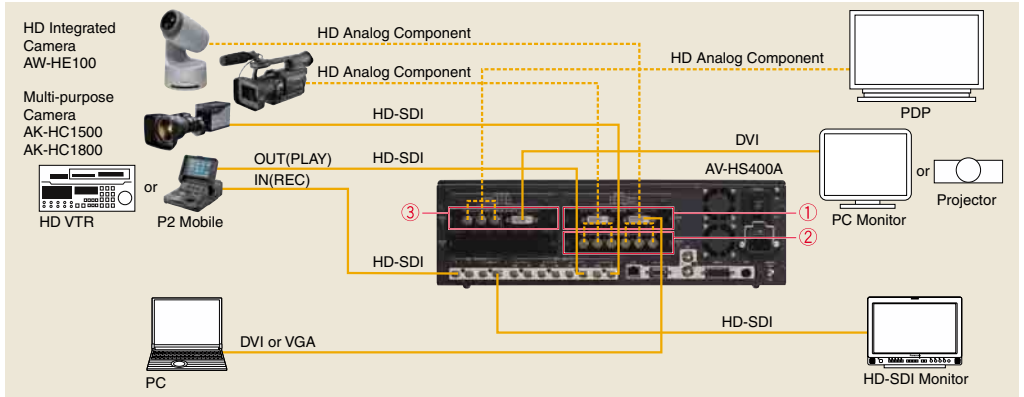

● Provides the flexibility required for facilities moving from SD to HD production.

1. A combined HD/SD-SDI and HD/SD analog component environment without Genlock.

- =Option Boards
- ① ANALOG INPUTS(AV-HS04M2)
- ② SDI INPUTS(AV-HS04M1)
- ③ DVI/ANALOG OUTPUTS(AV-HS04M5)
- ④ ANALOG OUTPUTS(AV-HS04M4)

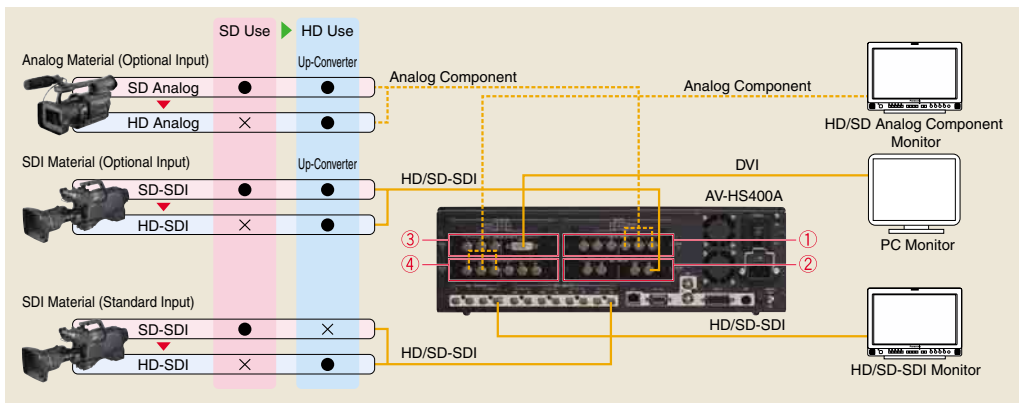

2. A combined HD/SD-SDI and analog composite environment without Genlock.

- =Option Boards
- ① ANALOG COMPOSITE INPUTS (AV-HS04M6)
- ② SDI OUTPUTS (AV-HS04M7)

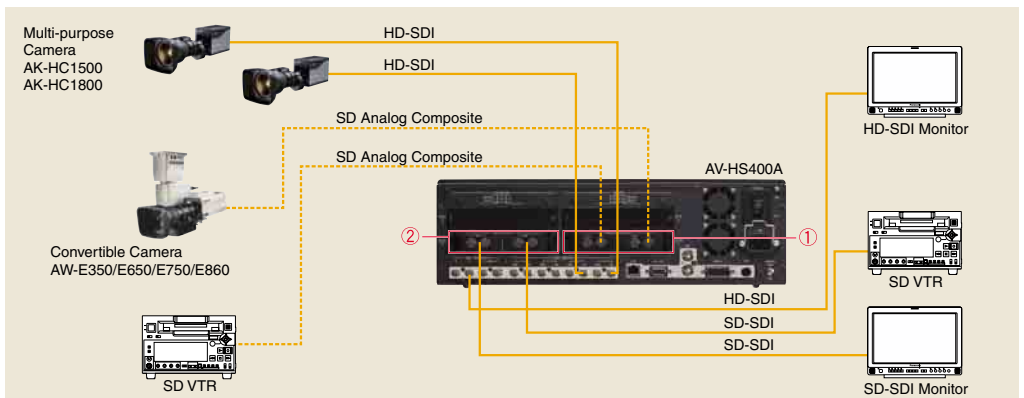

● Specifications

Video processing	Video format	SD (576/50i, 480/59.94i), HD (1080/59.94i, 1080/50i, 720/59.94p, 720/50p)
M/E		1M/E
Input	Video processing	Y:Cb:Cr, 4:2:2 10 bit RGB, 4:4:4 8 bit
	Video	Standard: Four inputs (HD/SD-SDI) Option: A maximum of four inputs (Up to 2 input boards (each board offering 2 inputs) for each of the following 4 types of boards may be added: HD/SD-SDI x 2, HD/SD-analog component x 2, analog composite x 2, DVI-I x 2.)
	Reference	Black burst/TRI (loop through) x 1
Output	Video	Standard: Four outputs (PGM x 2, general-purpose x 2, each HD/SD-SDI) Option: A maximum of four outputs (general-purpose x 4) (Up to 2 output boards (each board offering 2 outputs) for the following 3 types of boards may be added: analog component x 2, DVI-I/analog component x 1 each, HD/SD-SDI x 2).
	Reference	Loop through x 1 (Genlock/ Black burst x 2 (internal synchronization)

WIPE/DVE	Pattern	WIPE x 12, Squeeze x 11, SLIDE x 8, 3D DVE x 12 (3 directions) Selection with key transition is possible independently of background.
Transition	Transition method	FADER, AUTO
	Transition type	Cut, mix, wipe (including DVE), background and key can be selected.
KEYER	Key source	BUS
	Key fill	BUS, MATTE
PinP	Key mode	Linear key, Lum key, Chroma key (Key only), Full key (Key only)
	Transition method	AUTO (PinP only)
Interface	Transition type	MIX
	Serial (EDITOR)	D-sub9pin x 1: RS-422 (GVG protocol compatible), for controlling a pan-tilt system
	Tally output	D-sub15pin x 1, open collector output
	GPI	ø 3.5 Stereo mini jack
	LAN	RJ45, 10 Mbps x 1
Removable media	SD memory card slot	1 (for transferring still image files and providing an upgrade capability)
Humidity		10 % to 90 % (no condensation)
Operating temperature		0 °C to +40 °C (32 °F to 104 °F)
Power Supply / Power consumption		AC 100 V to 120 V, 50 Hz/60 Hz / Approx. 98 W
Dimensions (W x H x D)		420 mm x 132 mm x 408 mm (16-9/16" x 5-3/16" x 16-1/16" (excluding protrusions))
Weight		Approx. 6.4 kg (14.1 lbs): without options Approx. 7.2 kg (15.9 lbs): with options

* Features and specifications in this document are subject to change without notice due to continual improvements.

● Dimensions

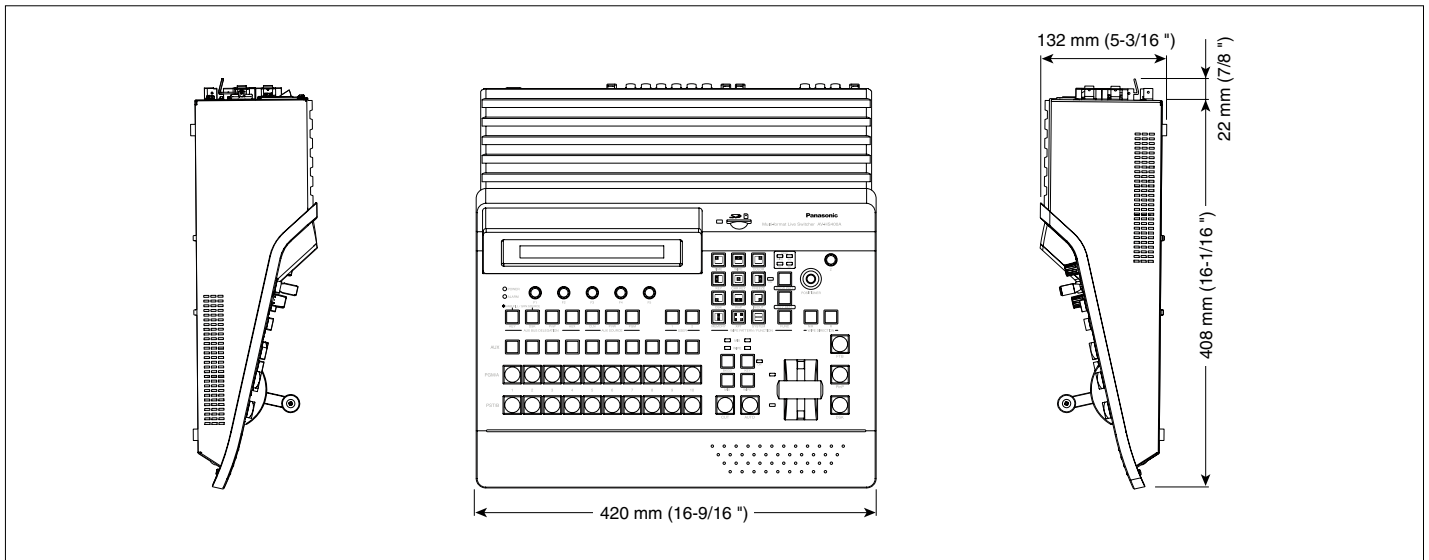

● SD Logo is a trademark.

Panasonic®

Panasonic Broadcast & Television Systems Co.

Unit of Panasonic Corporation of North America

www.panasonic.com/broadcast

Government Sales: phone: 201-348-7587

Headquarters: 3 Panasonic Way, 4E-7, Secaucus, NJ 07094; phone: 201-348-5300

Eastern Zone: 3 Panasonic Way, 4E-7, Secaucus, NJ 07094; phone: 201-348-7196

Western Zone: 3330 Cahuenga Blvd. West, Los Angeles, CA 90068; phone: 323-436-3608

AV-JACHS400A08

Printed in Japan